

# High-Attenuation Wideband Active Common-Mode EMI Filter Section

**Energy & Environment**

Electricity and Power Electronics

Energy Conservation/Generation/Management/Storage (Battery)

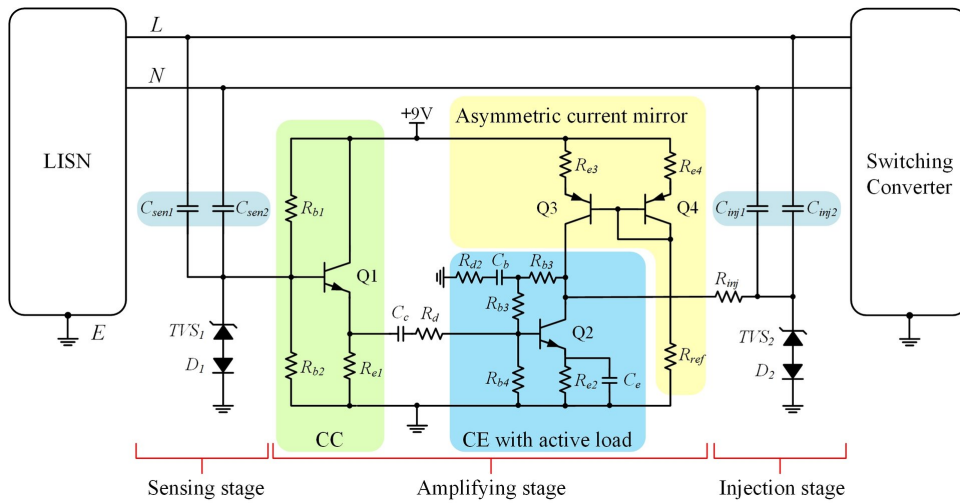

**IP Status**  
Patent filed

Technology Readiness Level (TRL) ?

4

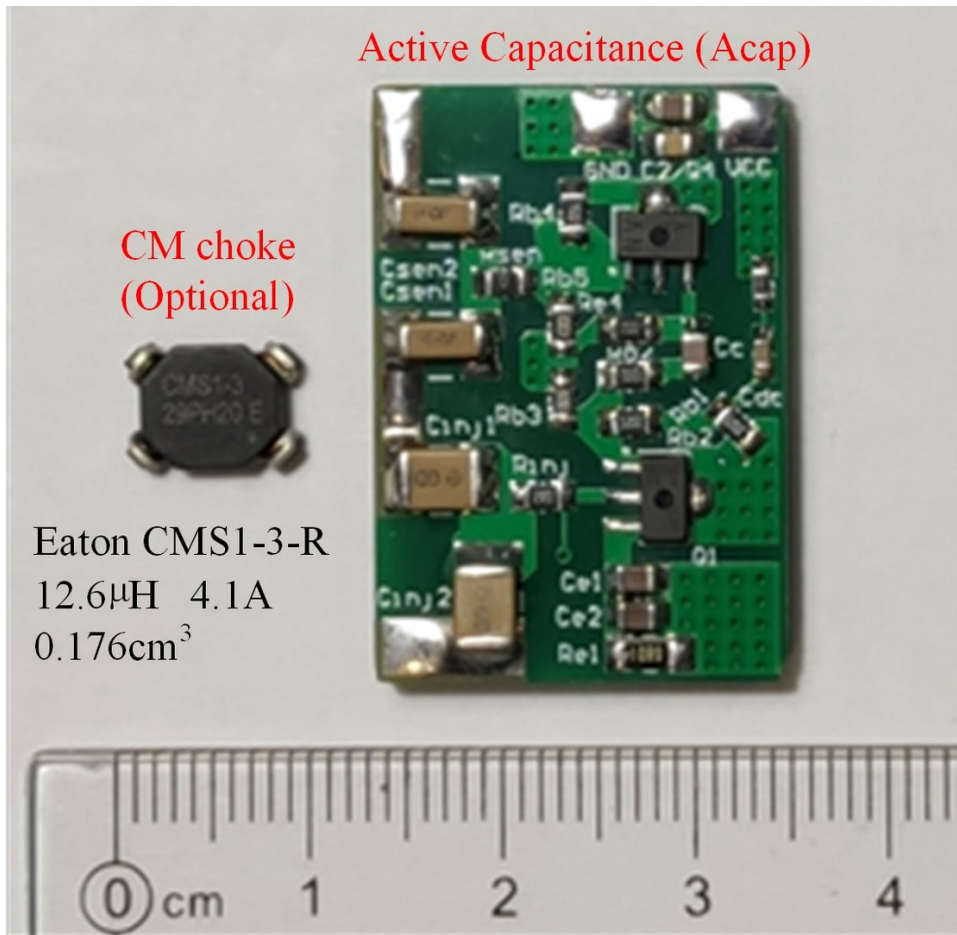

Inventor(s)

Prof. CHUNG Shu Hung Henry

Mr. ZHANG Kun

Enquiry: kto@cityu.edu.hk

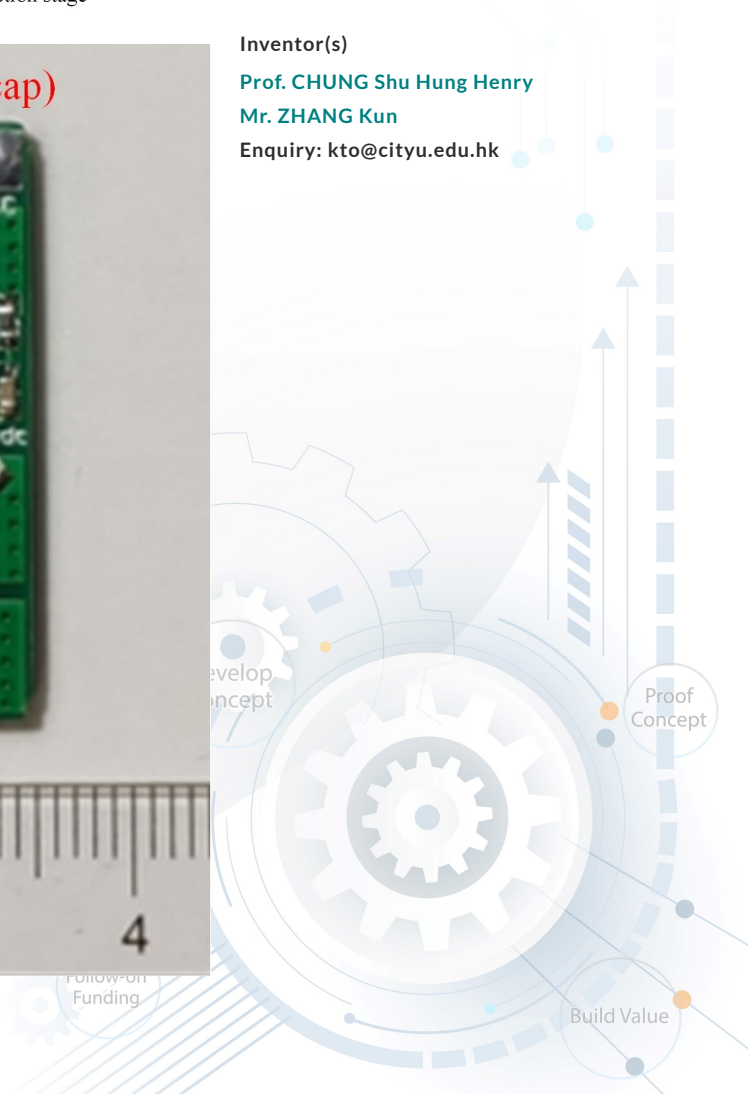

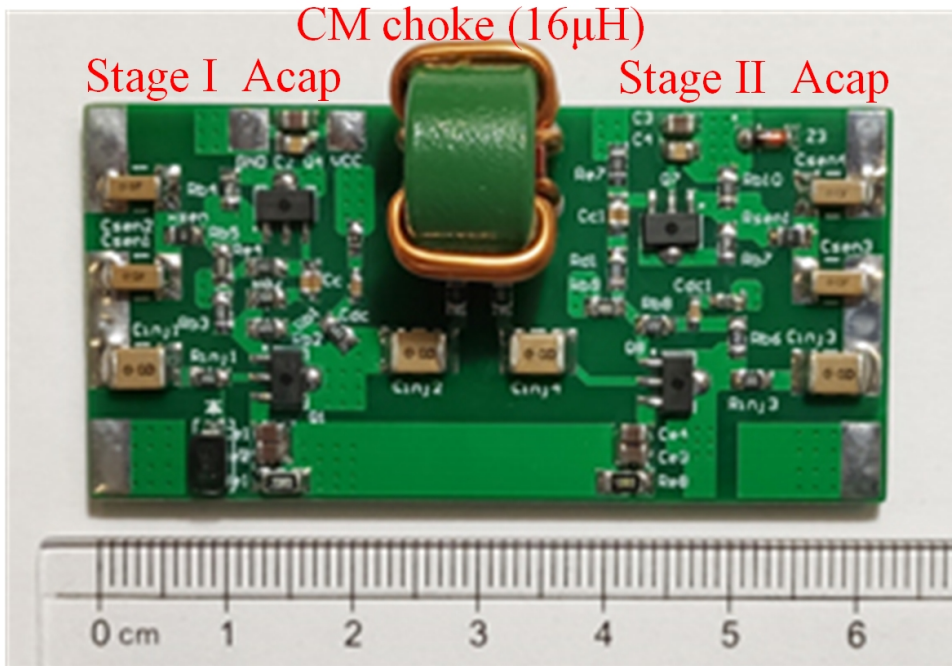

## Opportunity

With the global drive to advance semiconductor technology for new electronics and renewable energy conversion, semiconductor devices are becoming ever more power hungry. This requires switching-mode power converters to operate at an increasingly high switching frequency, generating a lot of electromagnetic interference (EMI). To date, it has been difficult to solve this problem, due to the limitations of conventional EMI filters. Voltage sensing and current compensation (VSCC) active EMI filters are the most promising approach, but their operating range is still too limited to handle high levels of EMI common-mode (CM) noise. Their bandwidth is relatively small, and their structure contains only one VSCC section. The current invention extends the concept of an active CM filter (ACF) by proposing a novel multistage VSCC ACF with low CM inductance. This invention offers an excellent candidate for alleviating ever higher levels of EMI noise in the future semiconductor industry.

## Technology

The proposed technology is a wideband active common mode filter (ACF) section that offers high attenuation of electromagnetic interference (EMI) noise. The section is composed of an active capacitor and a small CM inductor. The components of the active capacitor offer several advantages: low cost, fast response, and good immunity to high voltage transients. The working bandwidth of the ACF ranges from 150 kHz to 30 MHz. By cascading several of the proposed ACF sections, a multistage structure can be created, affording different levels of filtering attenuation. The number of cascaded sections is optimized according to the level of EMI noise. The performance of single-stage and two-stage versions of the proposed ACF has been tested with two commercial products. The EMI measurement results show that the proposed ACF is an effective solution for CM noise suppression.

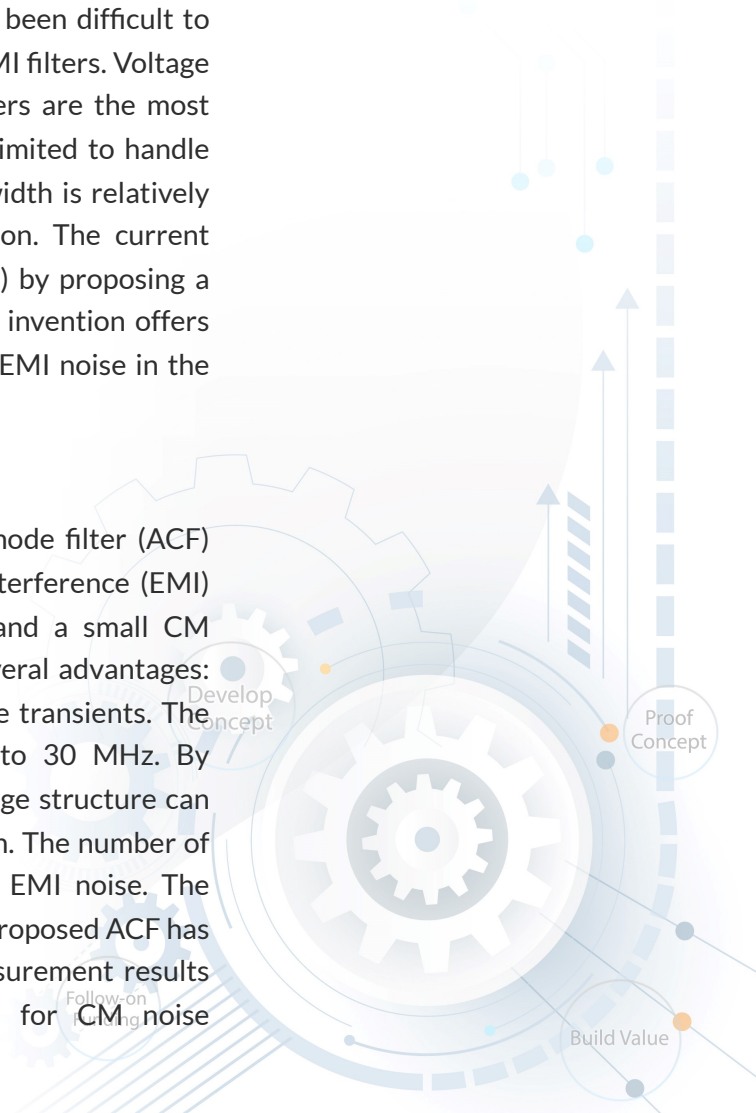

## Advantages

- Lighter, smaller, lower-cost device
- Wider bandwidth
- Higher attenuation of common-mode EMI noise
- General multistage VSCC structure that suits different applications.

## Applications

- Power supply manufacturers (proposed device already tested with two commercial products – 90 W rated power for laptop adaptor and 1000 W power supply representing industrial applications)
- Microelectronics companies seeking to control ever increasing levels of EMI noise with advances in semiconductor technology

