

Chapter 6

Etching

Professor Paul K. Chu

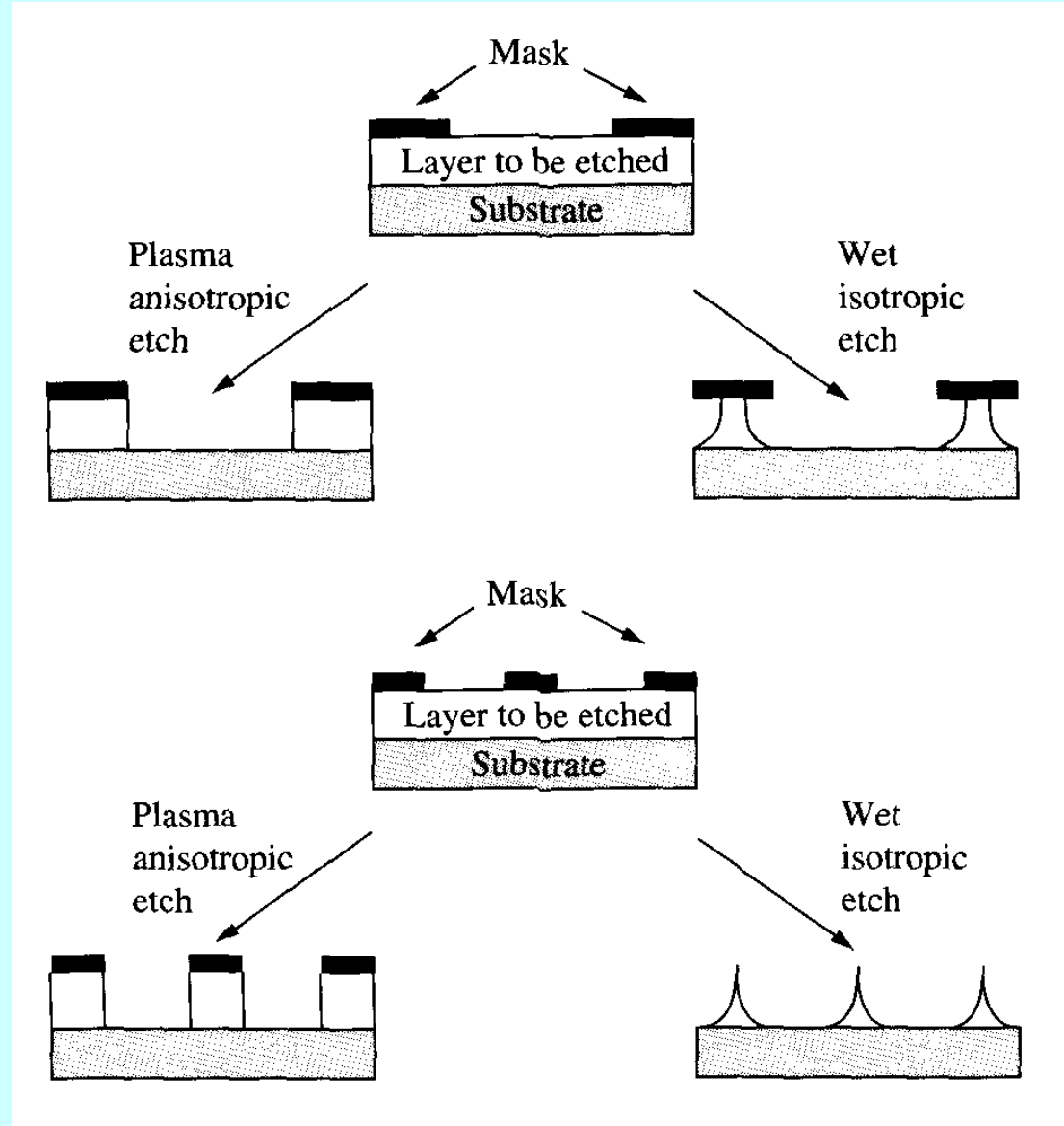

Wet Chemical Etching

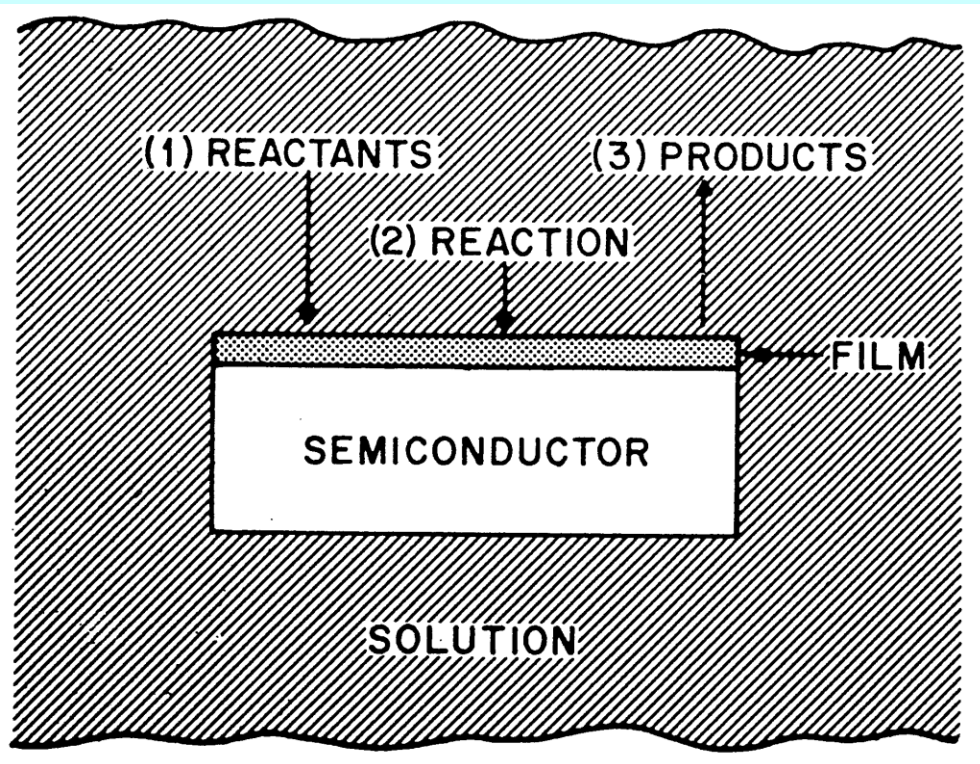

(1) Transportation of reactants to the reacting surface (e.g. by diffusion)

(2) Chemical reactions at the surface

(3) Transportation of the products from the surface (e.g. by diffusion)

Silicon Wet Etching

For semiconductor materials, wet chemical etching usually proceeds by oxidation, accompanied by dissolution of the oxide.

For silicon, the most commonly used etchants are mixtures of nitric acid (HNO_3) and hydrofluoric acid (HF) in water or acetic acid (CH_3COOH). The reaction is initiated by promoting silicon from its initial oxidation state to a higher oxidation state:

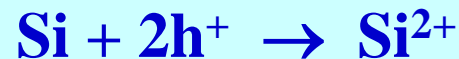

The holes (h^+) are produced by the autocatalytic process:

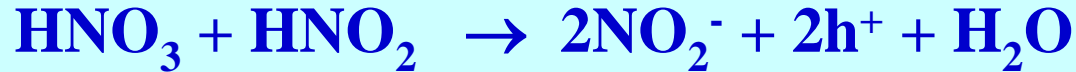

Si^{2+} combines with OH^- (formed by dissociation of H_2O) to form $Si(OH)_2$ which subsequently liberates H_2 to form SiO_2 :

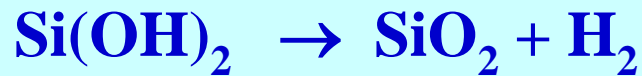

SiO_2 then dissolves in HF:

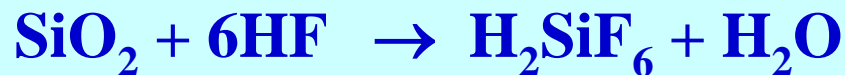

The overall reaction can be written as:



- Although water can be used as a diluent, acetic acid is preferred as the dissociation of nitric acid can be retarded in order to yield a higher concentration of the undissociated species
- At very high HF and low HNO_3 concentrations, the etching rate is controlled by HNO_3 , because there is an excess amount of HF to dissolve any SiO_2 formed
- At low HF and high HNO_3 concentrations, the etch rate is controlled by the ability of HF to remove SiO_2 as it is being formed. The etching mechanism is **isotropic**, that is, not sensitive to crystallographic orientation

Insulating / Metal Film Etching

- Etching of insulating and metal films is usually performed with chemicals that dissolve these materials in bulk form and involves their conversion into soluble salts and complexes
- Film materials will etch more rapidly than their bulk counterparts
- The etching rates are higher for films that possess poor microstructures or built-in stress, are non-stoichiometric, or have been irradiated

Isotropic / Anisotropic Etching

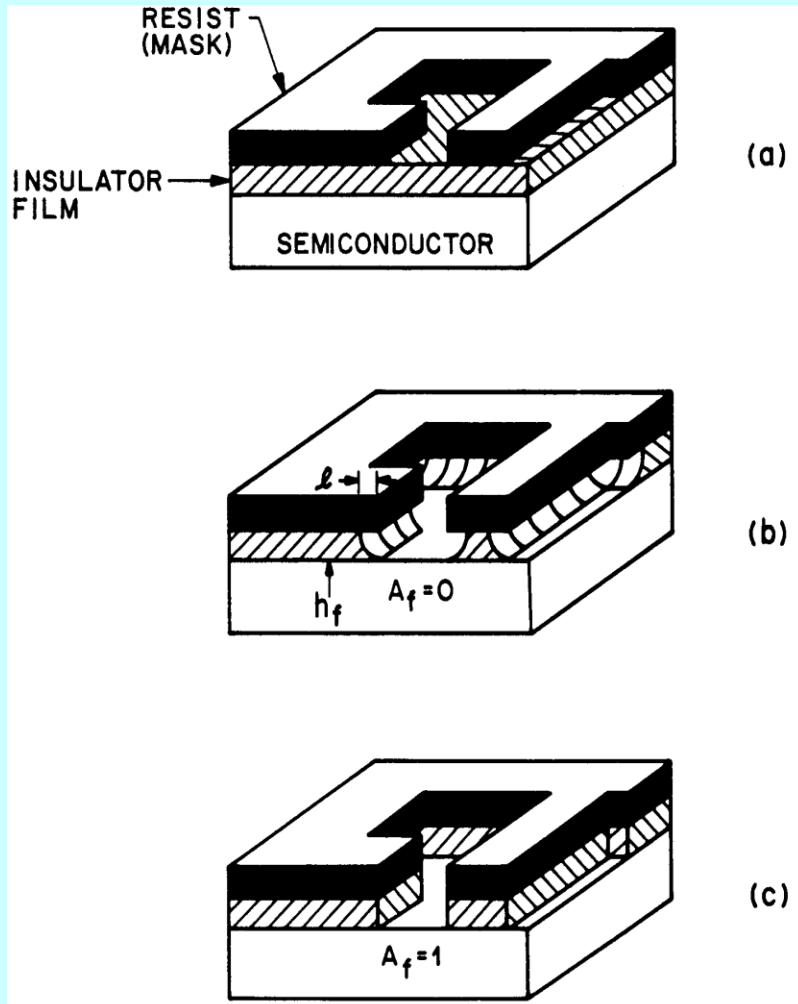

- Wet etching is usually isotropic, undercutting the layer underneath the mask and resulting in a loss of resolution in the etched pattern
- If patterns are required with resolution much smaller than the film thickness, anisotropic etching (i.e., $1 \geq A_f \geq 0$) must be used:

$$A_f = 1 - l / h_f = 1 - v_l / v_v$$

where A_f is the degree of anisotropy, and v_l and v_v are the lateral and vertical etch rates, respectively. For isotropic etching, $v_l = v_v$ and $A_f = 0$

Plasma

A plasma is a fully or partially ionized gas composed of ions, electrons, and neutrals. The plasma most useful to ULSI processing is a weakly ionized plasma called glow discharge containing a significant density of neutral particles (>90% in most etchers). Although plasma is neutral in a macroscopic sense, it behaves quite differently from a molecular gas, because it consists of charged particles that can be influenced by applied electric and magnetic fields

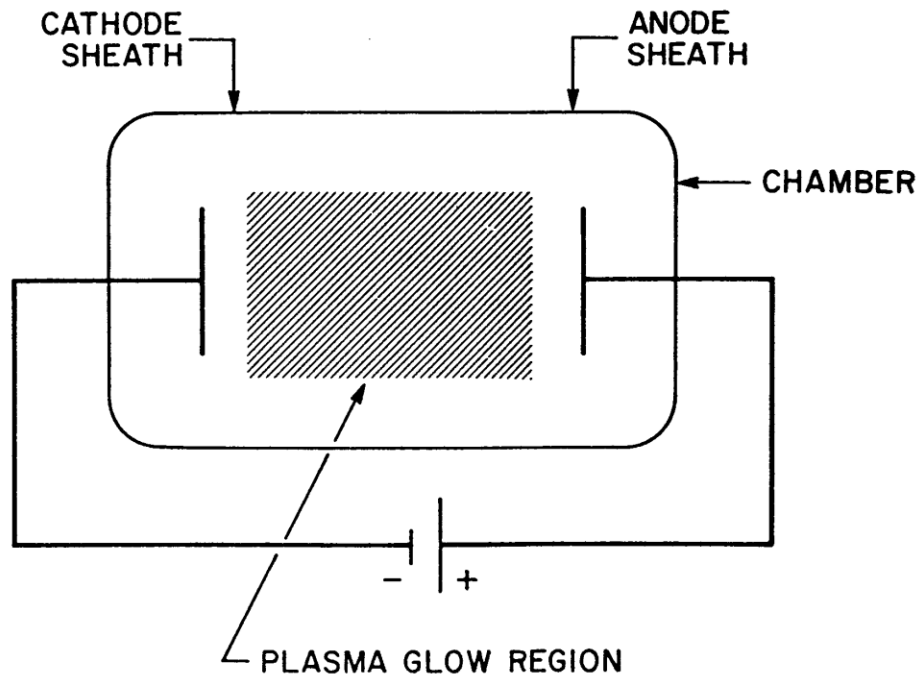

A plasma is produced when an electric field is applied across two electrodes between which a gas is confined at low pressure, causing the gas to break down and become ionized.

Simple DC (direct current) power can be used to generate plasma, but insulating materials require AC (alternate current) power to reduce charging.

In plasma etching, an RF (radio frequency) field is usually used to generate the gas discharge. One reason for doing so is that the electrodes do not have to be made of a conducting material. Besides, electrons can gain sufficient energy during oscillation to cause more ionization by electron – neutral atom collisions. As a result, the plasma can be generated at pressures lower than 10^{-3} Torr.

The free electrons released by photo-ionization or field emission from a negatively biased electrode create the plasma. The free electrons gain kinetic energy from the applied electric field, and in the course of their travel through the gas, they collide with gas molecules and lose energy. These inelastic collisions serve to further ionize or excite neutral species in the plasma via the following reaction examples:

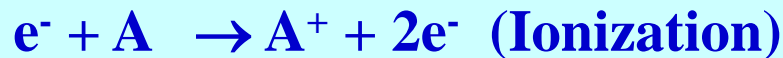
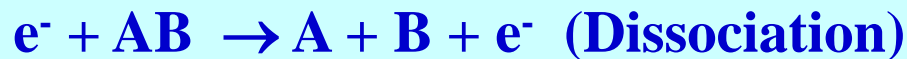

Some of these collisions cause the gas molecules to be ionized and create more electrons to sustain the plasma. Therefore, when the applied voltage is larger than the breakdown potential, the plasma is formed throughout the reaction chamber. Some of these inelastic collisions can also raise neutrals and ions to excited electronic states that later decay by photoemission, thereby causing the characteristic plasma glow.

- Interaction of plasmas with surfaces is often divided into two components: physical and chemical
- A physical interaction refers to the surface bombardment of energetic ions accelerated across the plasma sheath, and the loss of kinetic energy by the impinging ions causes ejection of particles from the sample surface
- Chemical reactions are standard electronic bonding processes that result in the formation or dissociation of chemical species on the surface

Plasma Etching Mechanism

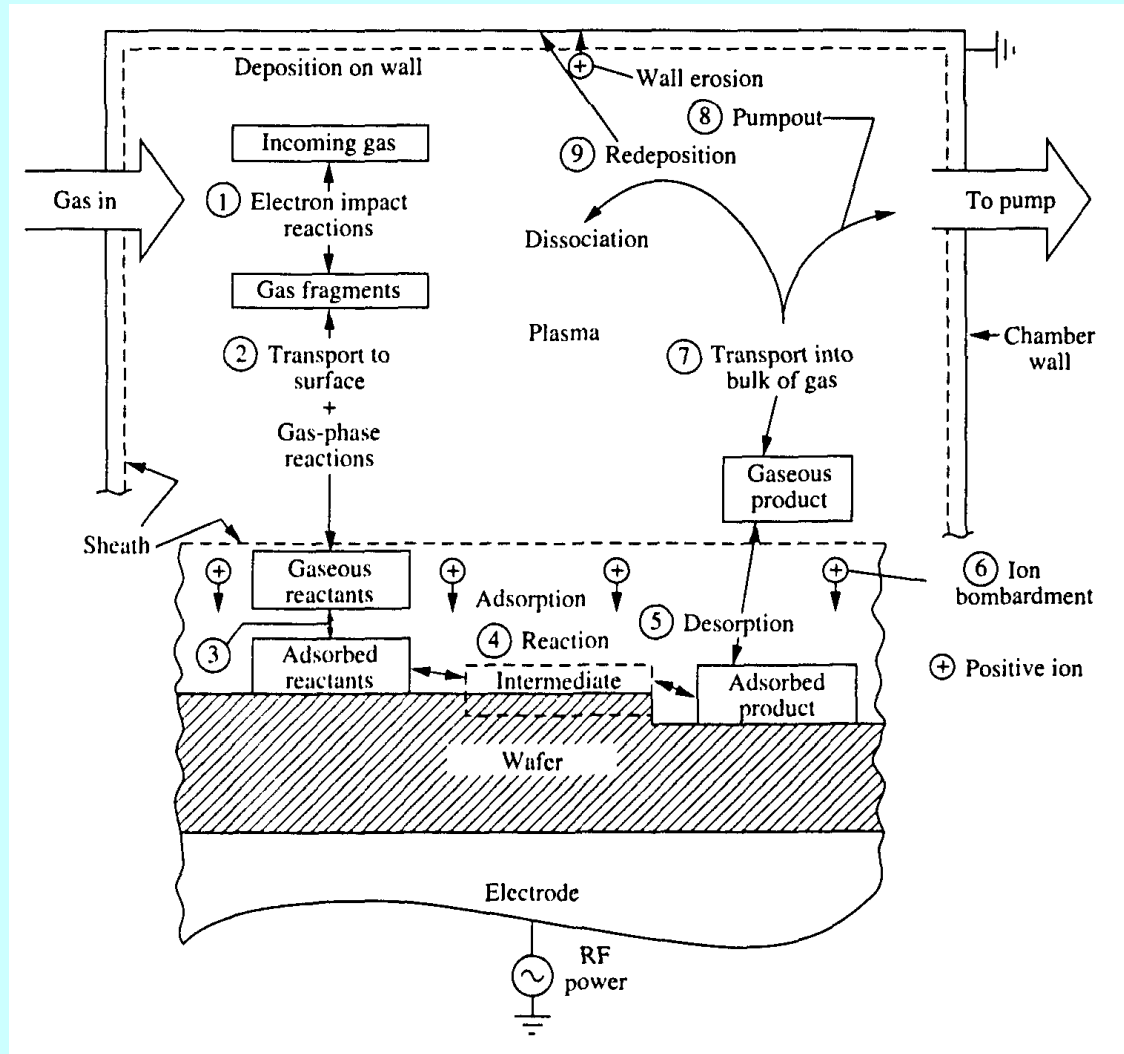

Sputtering Systems

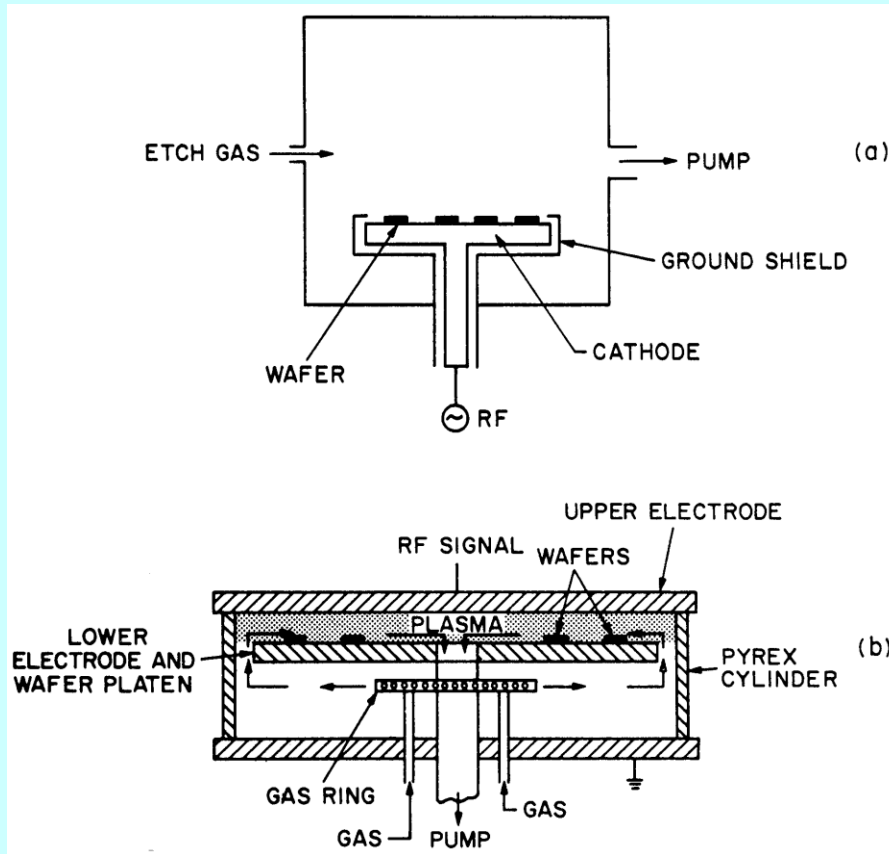

(Top) Sputtering - etching system: Inert gas ions accelerated by the applied electric field sputter off the surface. There is essentially no sputtering of the sidewalls to attain a high degree of anisotropy, but the selectivity is poor.

In reactive ion etching (RIE), the noble gas plasma is replaced by a molecular gas plasma similar to that in plasma etching. Under appropriate conditions, both RIE and plasma etching can give high selectivity and a high degree of anisotropy

(Bottom) Parallel - plate plasma etching system: The plasma is confined between the two closely spaced electrodes. Molecular gases containing one or more halogen atoms are fed through the gas ring.

Ion-Assisted Reaction

The etching rate can be enhanced by ion-assisted chemical reactions.

This figure depicts the etch rate as a function of flow rate of XeF_2 molecules with and without 1 keV Ne^+ bombardment. The lateral etch rate depends only on the ability of XeF_2 molecules to etch silicon in the absence of energetic ions impacting the surface, whereas the vertical etch rate is a synergistic effect due to both Ne^+ bombardment and XeF_2 molecules.

The degree of anisotropy can generally be enhanced by increasing the energy of the ions

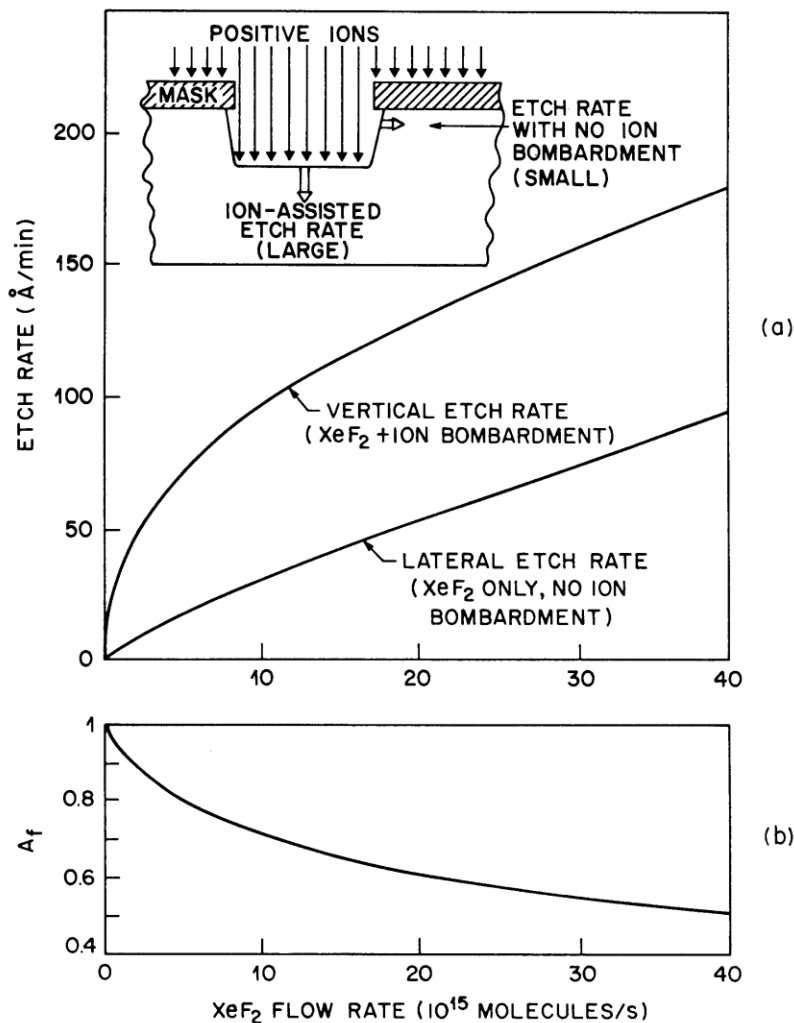

When a gas is mixed with one or more additive gases, both the etch rate and selectivity can be altered.

In this example, the etching rate of SiO_2 is approximately constant for addition of up to 40% hydrogen, while the etch rate for silicon drops monotonically and is almost zero at 40% H_2 .

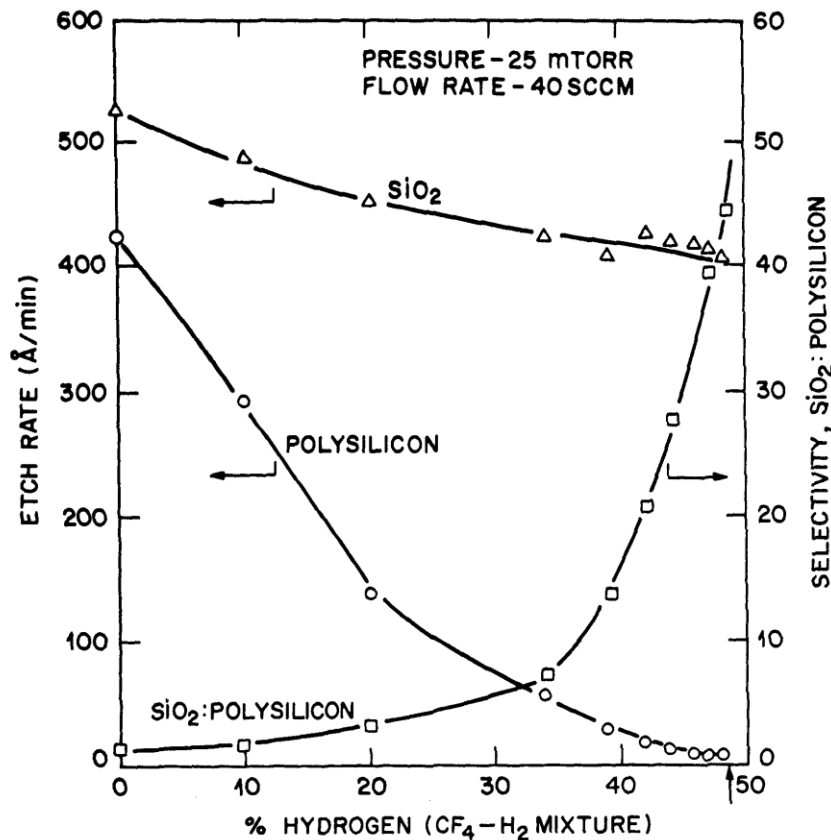

Selectivity (ratio of the etch rate of silicon dioxide to silicon) exceeding 45:1 can be achieved with CF_4 - H_2 reactive ion etching. This process is thus useful when etching a SiO_2 layer that covers a polysilicon gate.

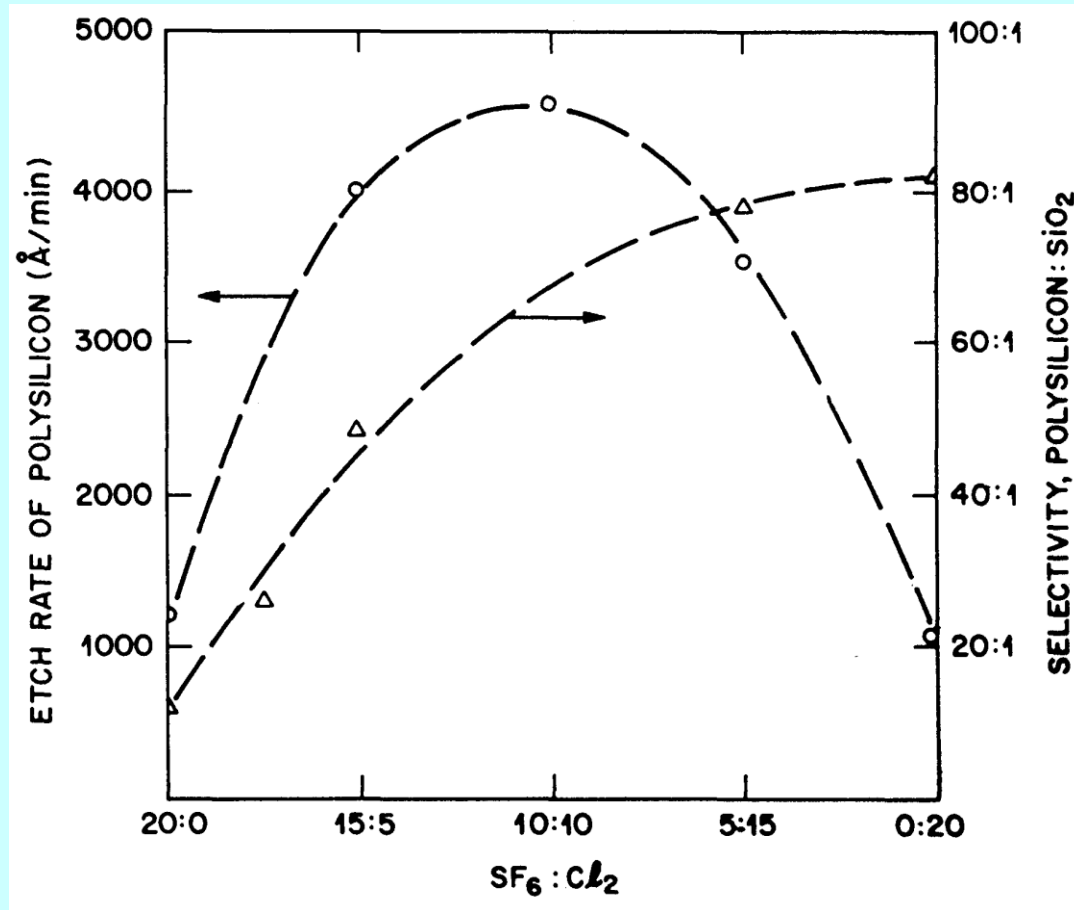

The etching rate of silicon can be adjusted to be 10 to 80 times faster than that of silicon dioxide by varying the gas composition of sulfur hexafluoride (SF₆) and chlorine.

Lift-Off versus Direct Etching

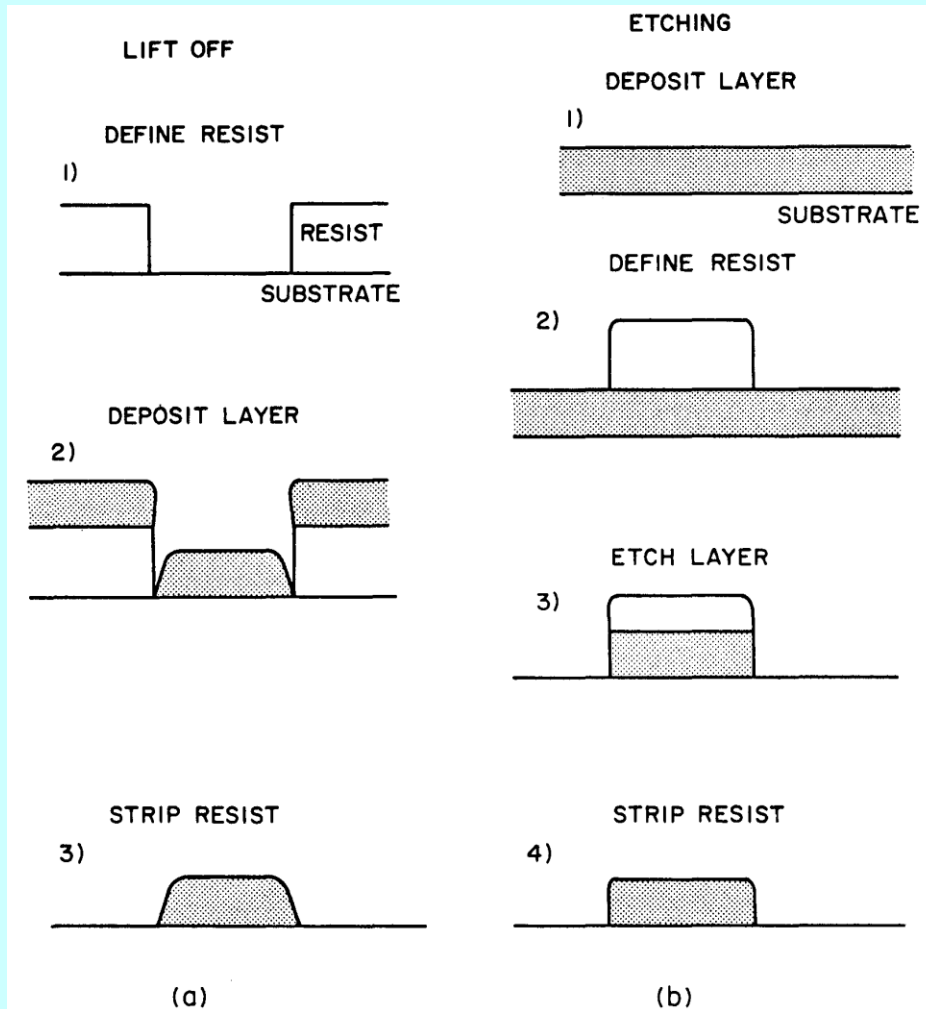

Disadvantages of the lift-off technique:

- (1) Rounded feature profile
- (2) Temperature limitations ($\geq 200^{\circ}\text{C}$ to 300°C)